

PCS edventures!™

Rub IQ™



FLIGHT MANUAL



COPYRIGHT NOTICE | Copyright © 2018 PCS Edventures, Inc. All rights reserved.

Permission is hereby granted to owners of this PCS Edventures! curriculum to make photocopies of the student pages ONLY, BUT use is restricted to students attending your program ONLY. Beyond this use, any reproduction of these pages for wider dissemination or for commercial sale is strictly prohibited. The content of this manual is furnished for educational use only, is subject to change without notice and should not be construed as a commitment by PCS Edventures, Inc.

RubiQ FLIGHT MANUAL

Get ready to meet RubiQ, your modular, open-source training drone! She'd get up to shake your hand, but as you can see, she's a little out of sorts right now. That's where you come in. This guide includes your step-by-step instructions for piecing RubiQ together. Follow them in reverse to disassemble. This kit includes all the parts and tools needed for assembly, along with a few spares for any accidents along the road. Once RubiQ is built, visit rubiq.edventures.com to access her online *Configuration Guide*. From there, you'll need to have the following standing-by in order to get RubiQ off the ground:

Battery: Any high-quality 3S 35C+ LiPo (2000-2500 mAh recommended)

Radio: Rubi's receiver is compatible with FrSky radios

FPV Goggles: Rubi's video transmitter is compatible with any 5.8 GHz goggles

Li-Po Compatible Balance Charger: Any

All these items are included in the full Discover Drones package and can be purchased, along with any spare parts, at edventures.com/collections/drones

DISCLAIMER:



CAUTION

- Drones are powerful and can be dangerous — RubiQ is no exception. Flying requires experience and thorough knowledge of flight safety. Only start flying after proper training and with a full understanding of the drone regulations in your area.
- When cared for properly, LiPo batteries provide the reliable, lightweight power that makes multirotor flight possible. However, LiPo batteries pose a severe fire hazard if improperly charged or poorly maintained. Review all battery warnings and instructions carefully, and follow all safety procedures when handling LiPo's.
- There's always a slight chance that RubiQ's motors could spin unexpectedly, causing bodily harm. Play it safe: remove her props when inside and disconnect the battery whenever possible!
- Be sure the video antenna is attached whenever you connect the LiPo battery! Powering up any drone without an antenna may cause permanent damage to the VTX (video transmitter).

PCS Edventures accepts no responsibility, or liability, for any injury, or damage, to persons or property, caused by the use of RubiQ, radio transmitters, FPV goggles, LiPo batteries or LiPo battery chargers. PCS Edventures also accepts no responsibility for damage caused to RubiQ by operating without a TX antenna installed or by connecting cables in an improper configuration.

INVENTORY

To build RubiQ, you'll need:

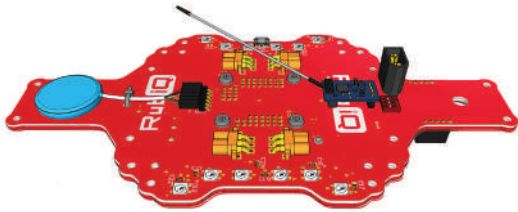

Power Distribution Board (PDB)
(Qty 1)

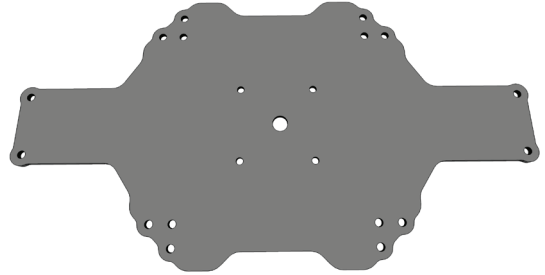

Lower Chassis
(Qty 1)

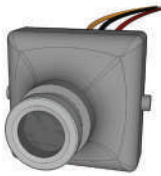

FPV Camera
(Qty 1)

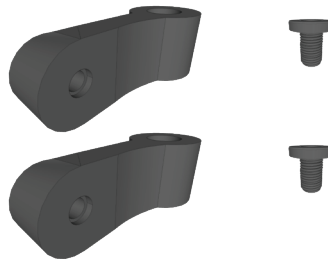

Camera Mounts & Camera Screws
(Qty 2)

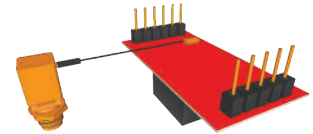

Video Transmitter (VTX)
(Qty 1)



Arms
(Qty 4)



CW Motors
(Qty 2)

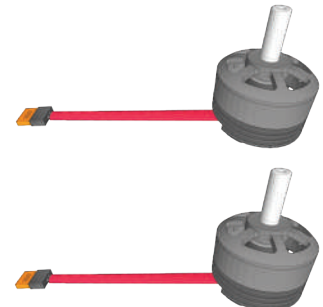

CCW Motors
(Qty 2)

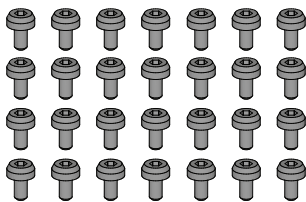

M3x6 Screws
(Qty 28)

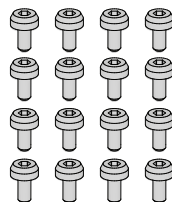

M3x7 Motor Screws
(Qty 16)

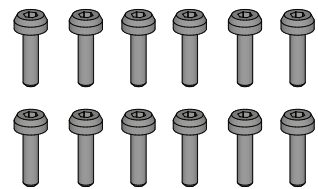

M3x12 Screws
(Qty 12)

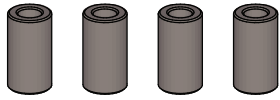

12mm Standoffs
(Qty 4)

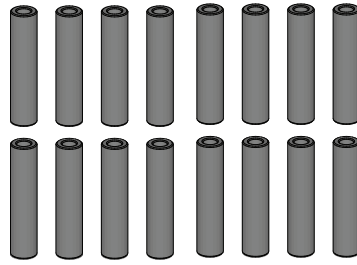

25mm Standoffs
(Qty 16)

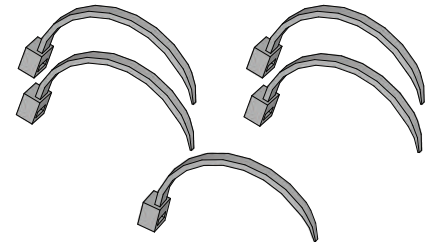

Zip Ties
(Qty 5)



Battery Plate
(Qty 1)



Battery Strap
(Qty 1)

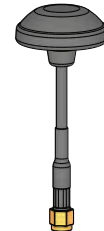

TX Antenna
(Qty 1)

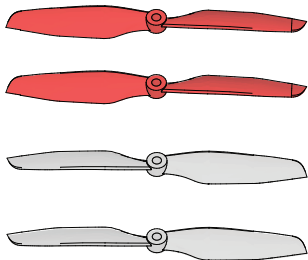

Props
(Qty 4)

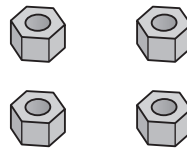

Prop Nuts
(Qty 4)

EXTRA PARTS:

- Camera Mounts and Camera Screws
- M3x6 Screws
- M3x7 Motor Screws
- M3x12 Screws
- 12mm Standoffs
- 25mm Standoffs
- Zip Ties
- Props
- Prop Nuts

LEGEND:



FLIP



REPEAT 2 TIMES

POWER DISTRIBUTION BOARD

TOP VIEW:

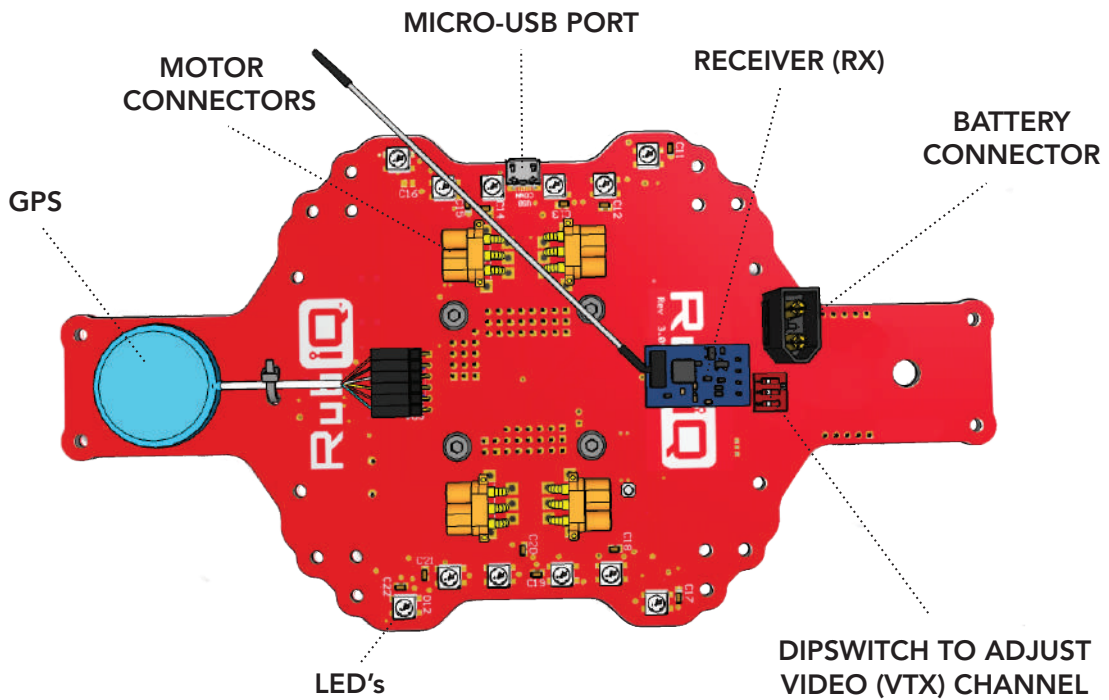

BOTTOM VIEW:

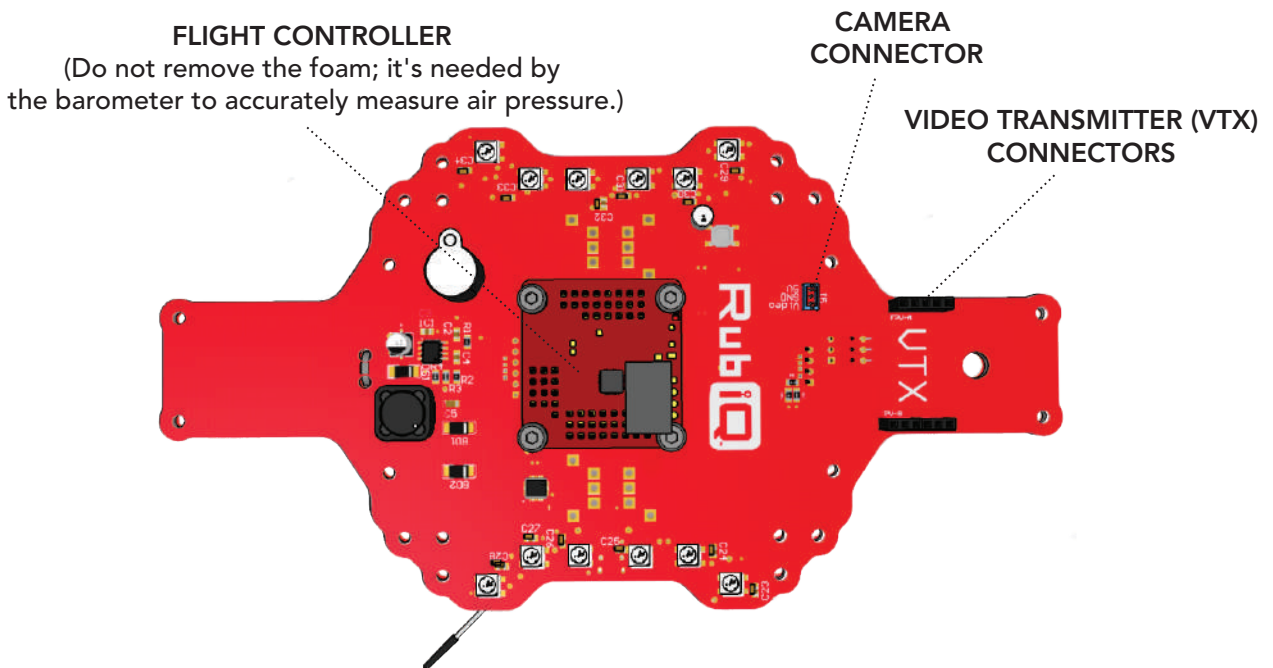



BUILD PLAN & CONFIGURATION GUIDE

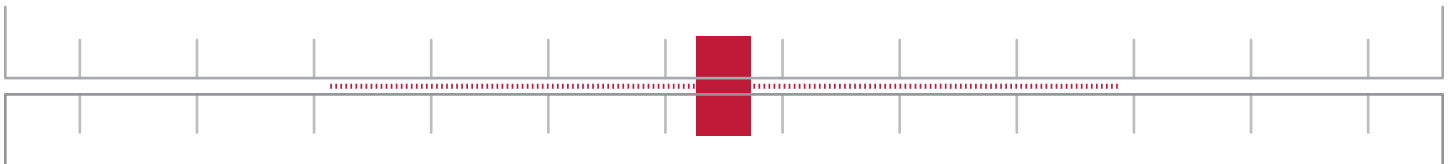

PARTS

1

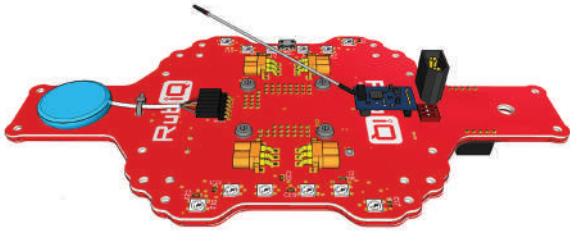

Power Distribution Board (PDB)

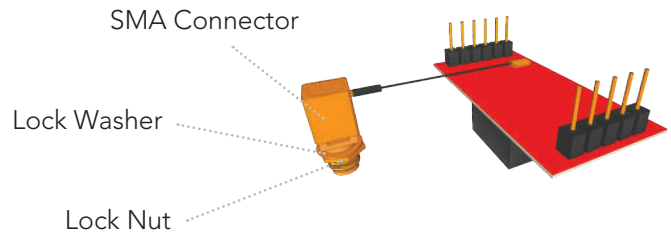

Video Transmitter (VTX)

ASSEMBLY



CAUTION

Orient the VTX so each pin slides into its own connector.

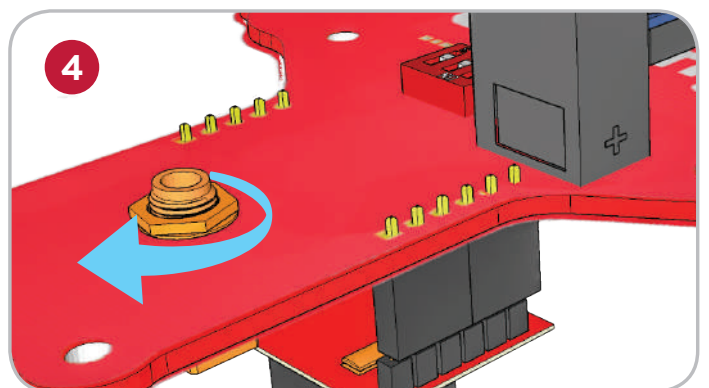
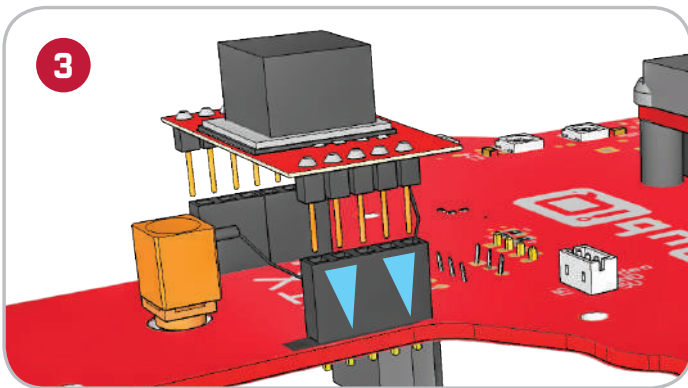
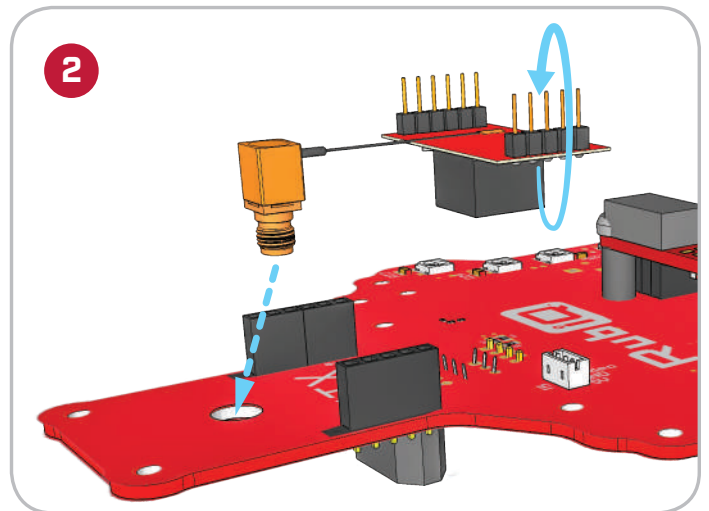
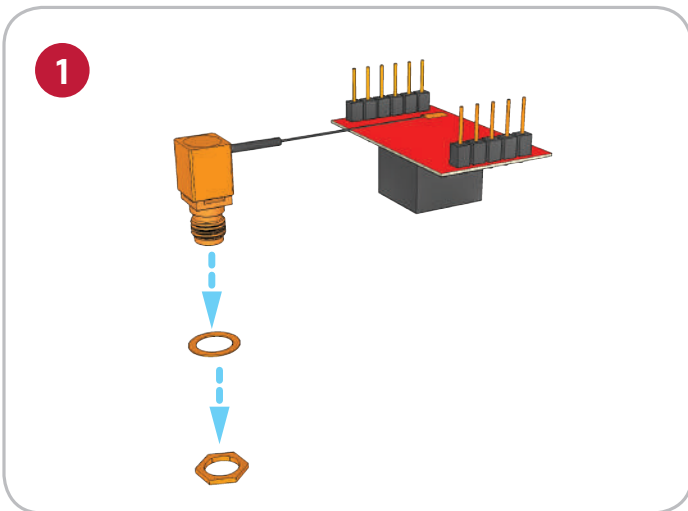

CAUTION

Hold the SMA connector below the board and tighten the nut with the prop wrench until snug. Do not allow the SMA connector to twist as you tighten to avoid damaging the cable. Do not overtighten to avoid stripping the threads.

PARTS



Camera Mounts

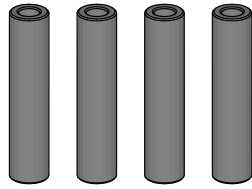

25mm Standoffs

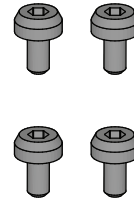

M3x6 Screws

ASSEMBLY



CAUTION

Attach all screws as firmly as possible to keep the frame stable during flight.

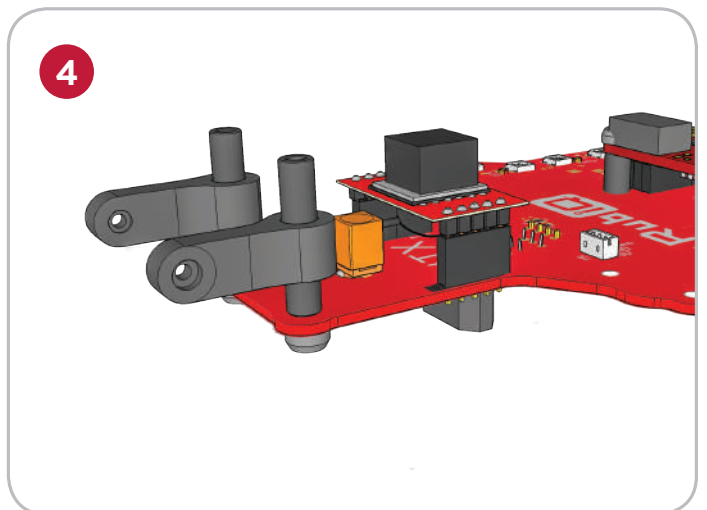
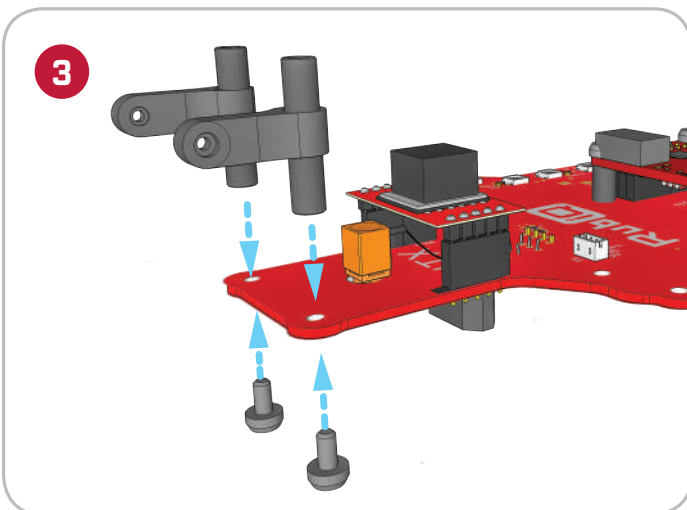
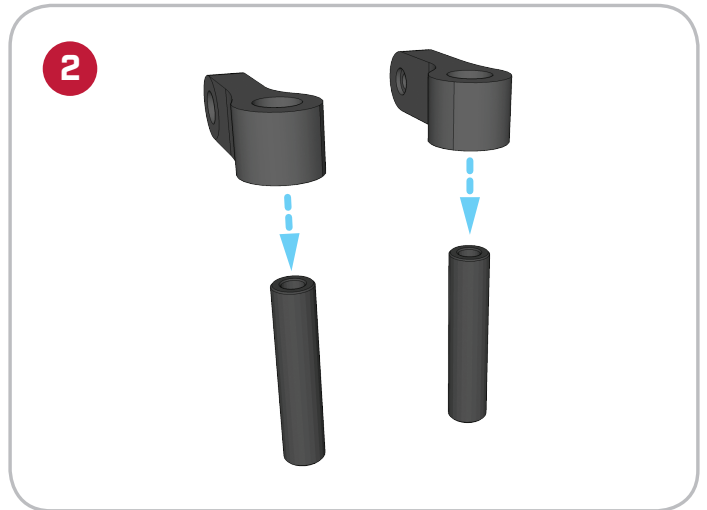
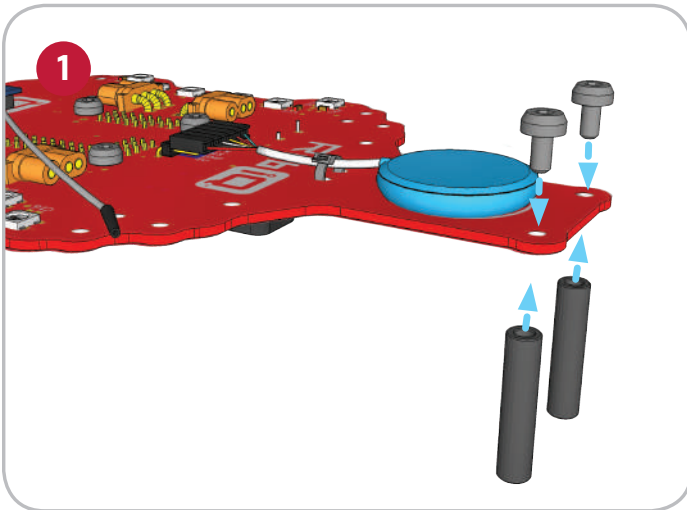

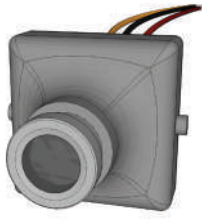

FPV Camera



Camera Screws

ASSEMBLY

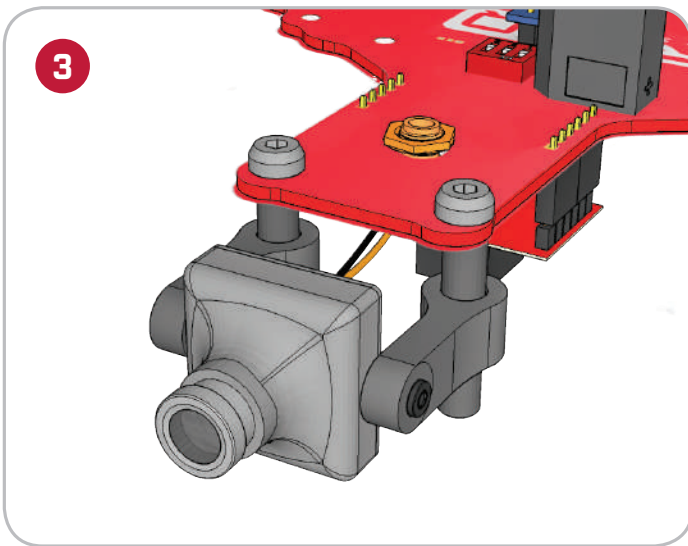
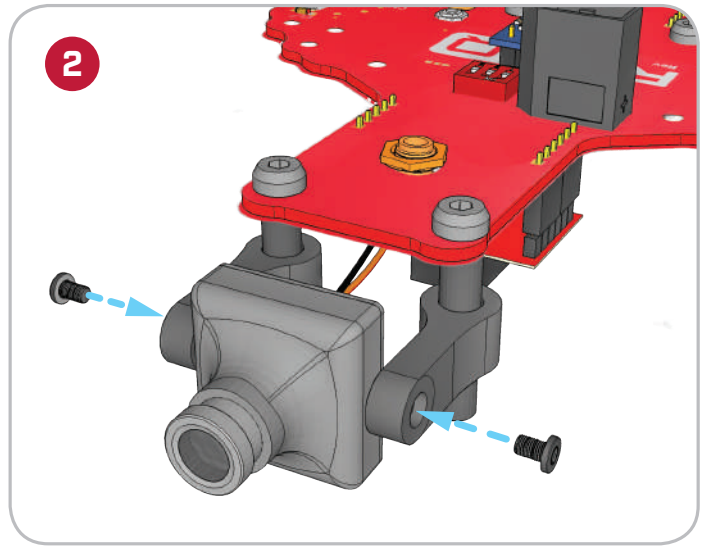
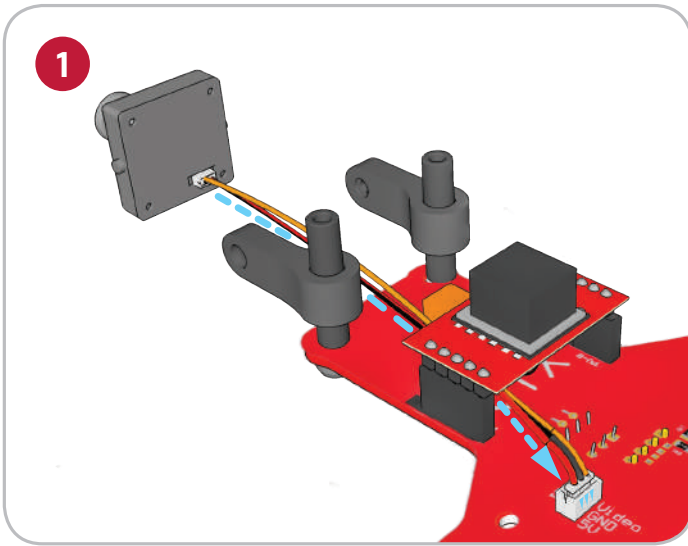

Attach camera with wires close to PDB for right-side-up camera feed.

PARTS



CW Motors



CCW Motors



Arms

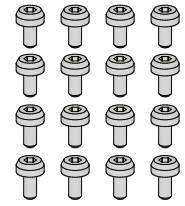

M3x7 Motor Screws

ASSEMBLY



Motors only attach to one side of the arms. Visually line up the mounting holes in the arms with the mounting holes in the motors before inserting screws to ensure motors are attached to the correct side of the arms.

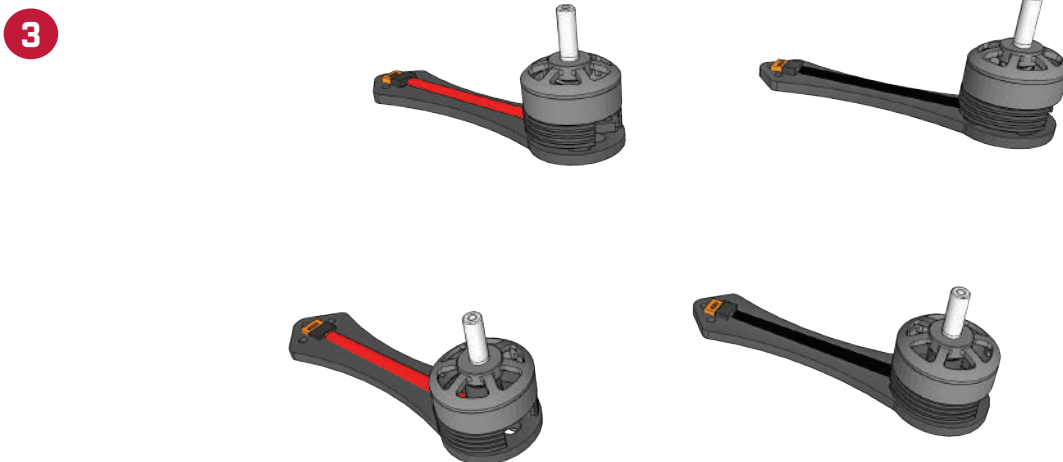
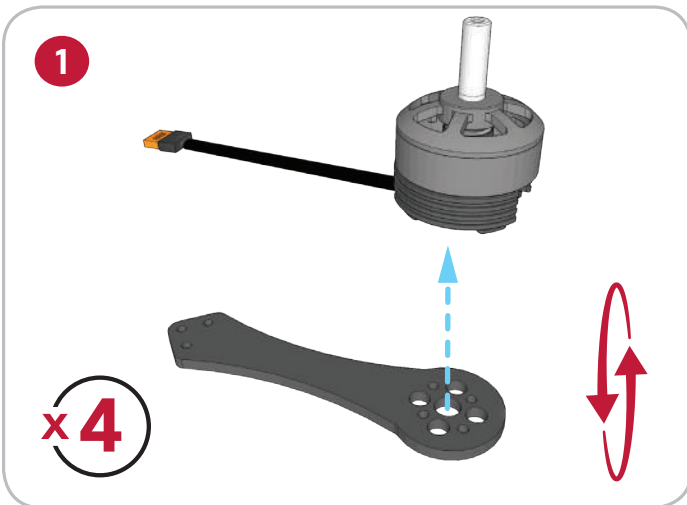

PARTS

5

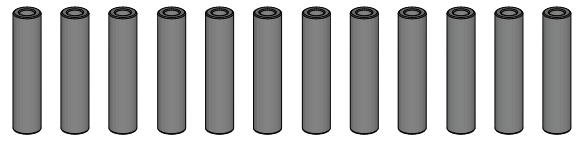
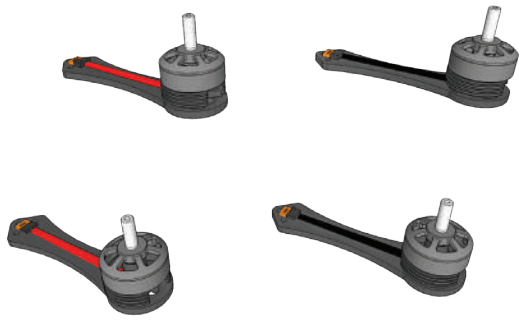

25mm Standoffs

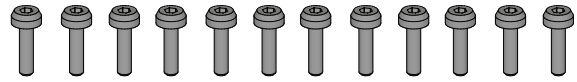

M3x12 Screws

ASSEMBLY

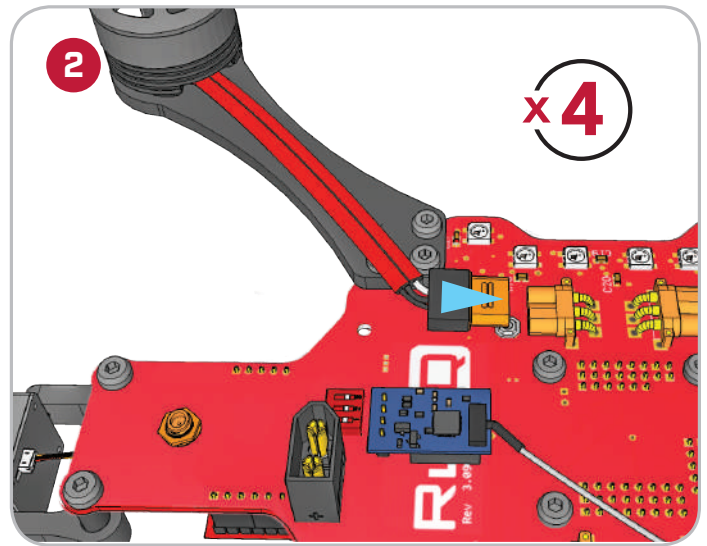
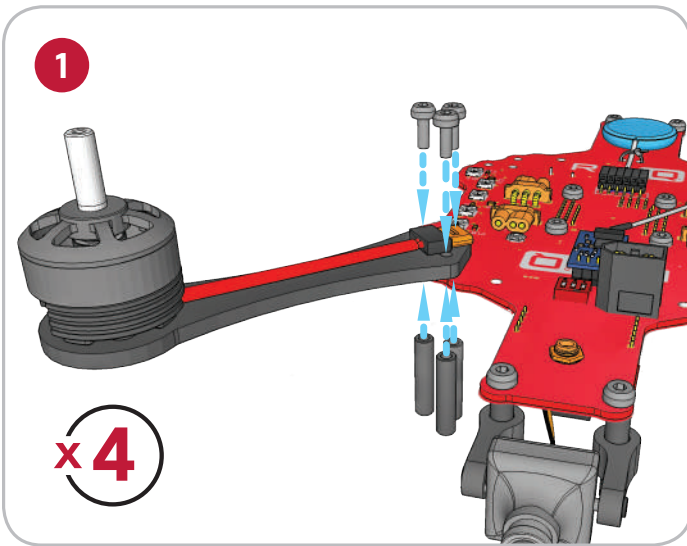

CW

CCW



CAUTION

Install all four arms as shown, with matching cables diagonal to each other to avoid erratic behavior in flight.

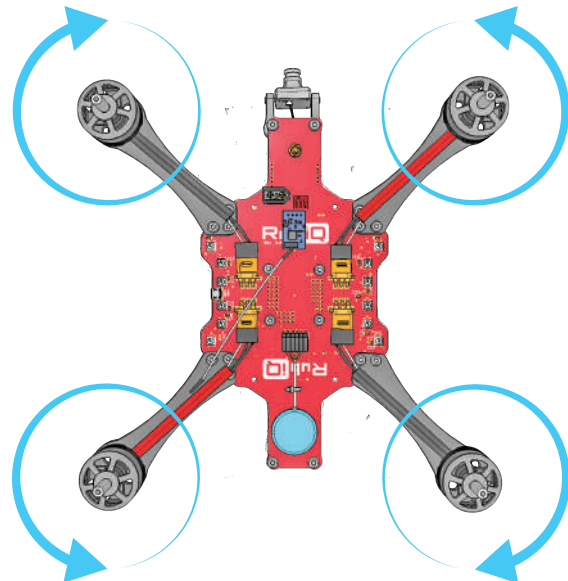

CCW

CW

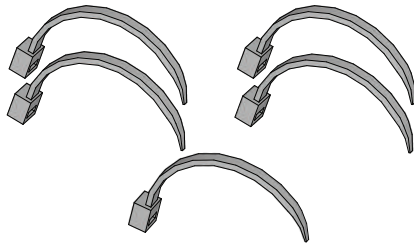

Zip Ties

ASSEMBLY

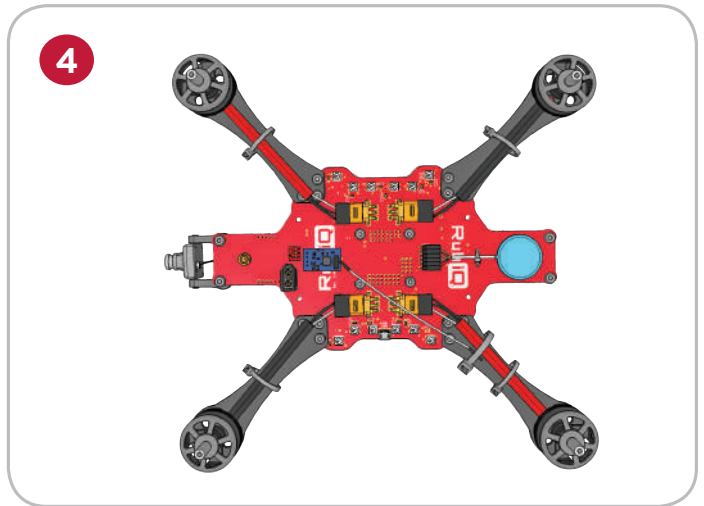
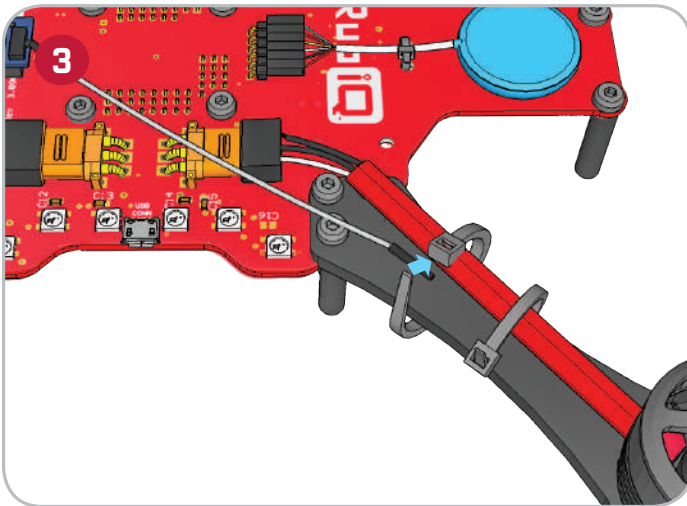
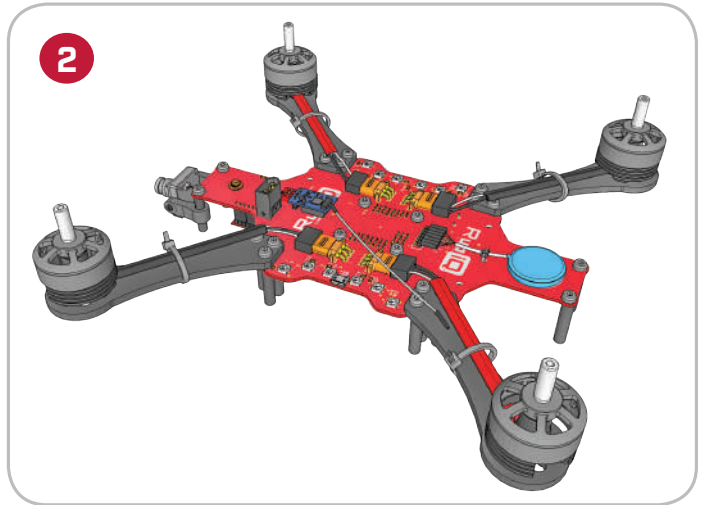
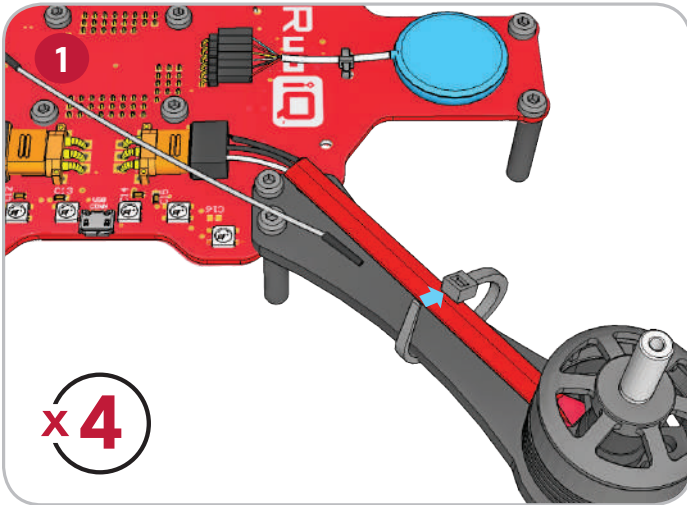

Leave some slack when securing the receiver's antenna. Too much tension will cause the wire to separate and permanently damage the RX.

PARTS

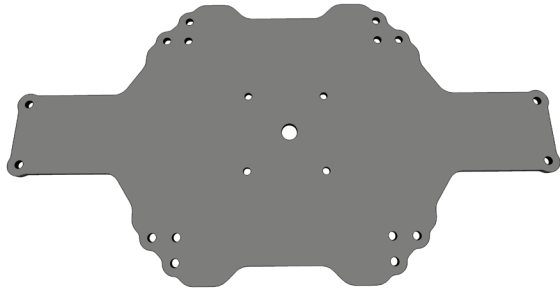

Lower Chassis

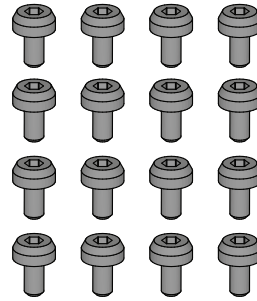

M3x6 Screws

ASSEMBLY

1

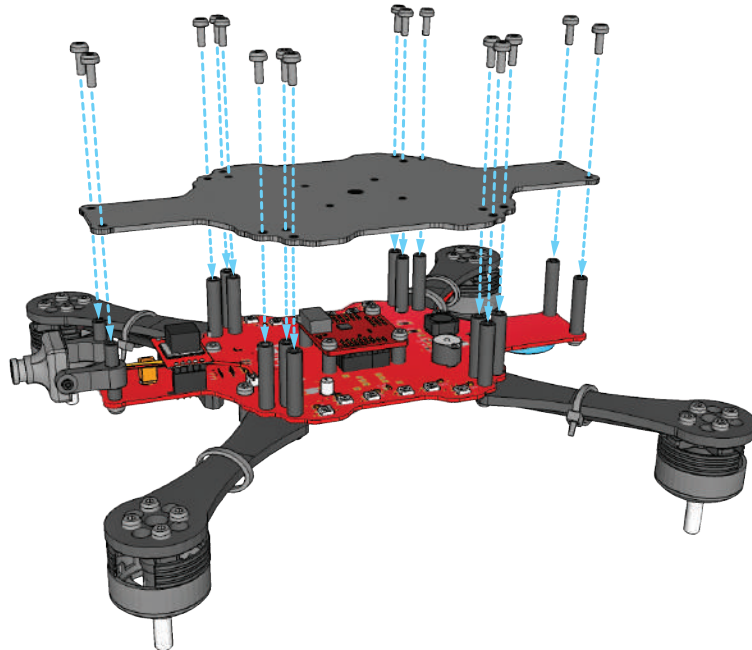

2

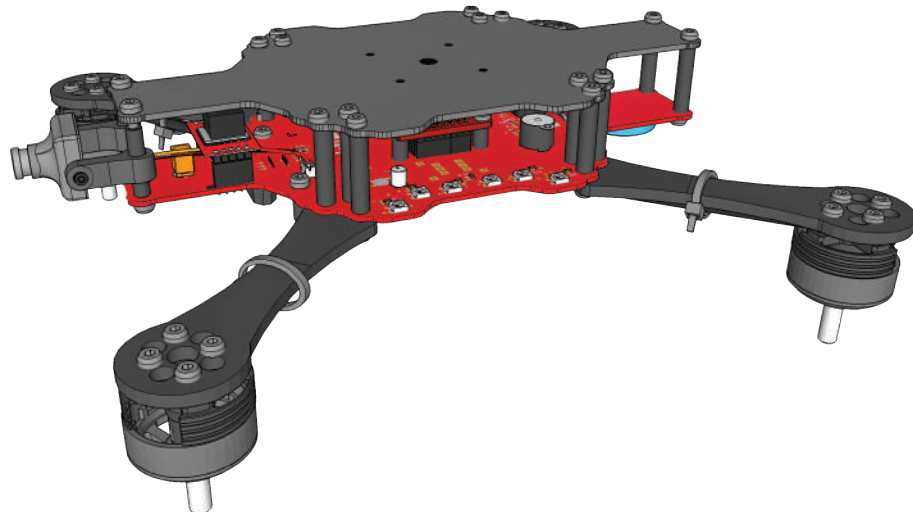

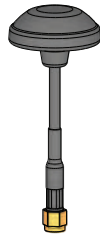

TX Antenna

ASSEMBLY



CAUTION

Always attach the TX antenna before connecting RubiQ to power to avoid permanently damaging the VTX.

1

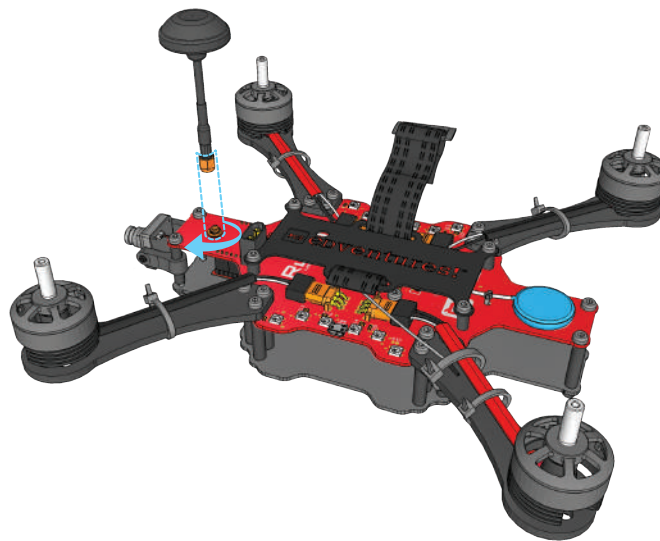

2

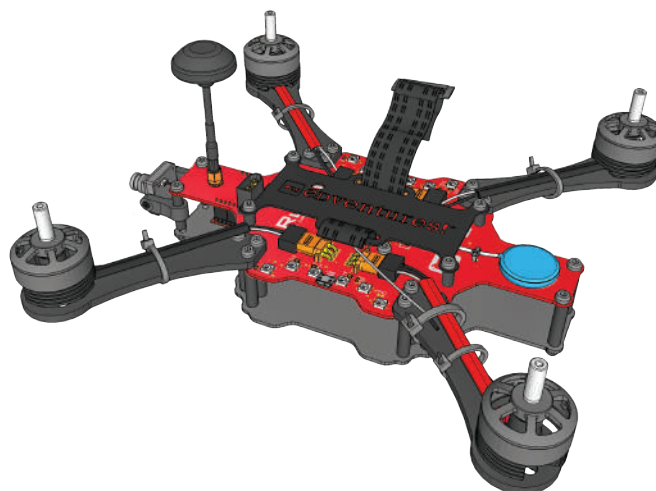

POST-BUILD INSPECTIONS



Make sure the VTX is properly installed so that none of the pins are exposed (see Step 1).



Make sure the VTX antenna base has been securely fastened with a wrench (see Step 1).



Make sure the camera cables exit from the top of the camera, close to PCB (see Step 3).



Make sure the arms with CCW (red) and CW (black) cables are installed with matching colors diagonal from each other (see Step 5).



Make sure the hole in battery plate is directly above the receiver (RX) (see Step 9)



Always make sure props are removed before connecting to the battery indoors.



Always wear safety glasses when connecting the battery.

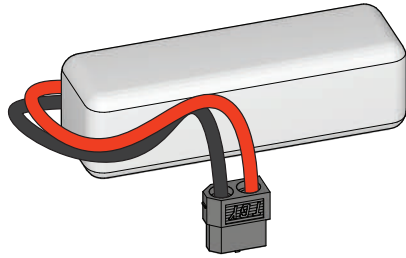

ASSEMBLY



FIRE RISK

Always charge and store LiPo batteries inside a fireproof container.



CAUTION

Tighten battery strap as firmly as possible to avoid shifting during flight.

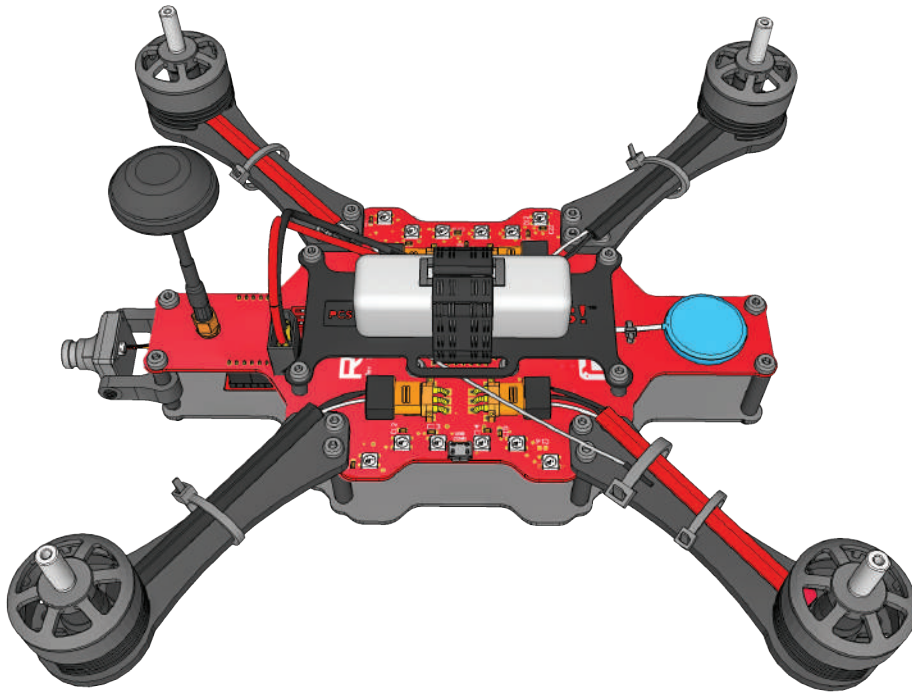

CAUTION

To unplug the battery, hold onto the battery connector and pull straight up; DO NOT pull directly on the wires and DO NOT wiggle the battery connector side to side when removing it from the board. Side to side motion will weaken the connection between the battery and the board.

CONFIGURATION GUIDE

COMPONENTS



CONFIGURATION

Visit rubiq.edventures.com, click on *Configuration* in the top right corner of the page and begin the RubiQ configuration process.

Step 1. Bind the RX to the Radio Controller.

Step 2. Verify RX Channels.

Step 3. Verify AUX Channels & Failsafe.

Step 4. Verify Switches.

Step 5. Verify LED's.

Step 6. Verify Motor Rotation.

Step 7. Calibrate ESC's.

Step 8. Calibrate Accelerometer.

Step 9. Set Magnetic Declination.

Pre-arming checks	
UAV is levelled	✓
Run-time calibration	✓
CPU load	✓
Navigation is safe	✗
Compass calibrated	✗
Accelerometer calibrated	✓
Hardware health	✓

At the end of a successful configuration, INAV's Pre-arming checks, found in the Setup tab, will show all categories with a green check mark except for "Compass Calibrated" and "Navigation is safe." This is for two reasons:

- The compass needs to be calibrated outside as part of the pre-flight check.
- RubiQ comes with GPS lock enabled, which means she won't indicate that navigation is safe or be able to fly without first connecting to seven satellites, something she can only do while out at the flight field.

Follow the *Pre-Flight Checklist* on the following page to fully prepare RubiQ for liftoff. If you reconnect RubiQ to INAV after the compass has been calibrated and she's locked onto the satellites, "Navigation is safe" will give you the green light.

PRE-FLIGHT CHECKLIST

BEFORE HEADING OUTSIDE

- Are you aware of and in compliance with all local and federal regulations?
- Is the flight field clear of hazards that would make it unsafe to fly?
- Are the weather conditions safe for flight?
- Do you have emergency equipment, including a first aid kit and means of fire suppression?

OUTSIDE



CAUTION

Do not attach props until Step 8 of the Pre-Flight Check.

1. Ensure all screws and components are securely fastened to the drone.

2. Set RubiQ on a flat launch surface. The accelerometer and gyro sensors calibrate automatically each time they are connected to power. To get the best calibration settings, RubiQ needs to be on a level surface during power-up.

3. Strap the LiPo battery to the battery plate (see Step 9 of the Build Plan). Tuck the balance cables under the battery strap, so they're protected during flight.

4. Wait for GPS lock. Plug in the battery, then listen for the beep tones and watch for the outer LEDs to blink green at least seven times. Each green blink equals one connected satellite. *Note: RubiQ will not arm without GPS lock. This may take several minutes, depending on the conditions.*

5. Make sure the drone and the radio are bound. Power on the radio controller and look for a solid light of RubiQ's RX or flip the beeper switch to test the connection.

6. Calibrate the compass. Move the radio's sticks to the position shown. When the drone starts beeping, release the sticks and spin the drone with each of its six sides facing down. You'll have 30 seconds before the beeping stops and the calibration is completed.

7. Check the failsafe. It should be set to disarm the motors if the drone ever flies out of range and loses connection to the radio. To test the failsafe settings, start with the throttle down, props off and all the switches away from you. Then, arm RubiQ. While the motors are spinning, power down the radio to simulate losing connection. RubiQ should stop her motors. *If the motors continue to spin, reset the failsafe and repeat this step.* (see Step 4 of the Configuration Guide at rubiq.edventures.com)

8. Unplug the battery and attach your props. (see Step 12 of the Build Plan)

9. Make sure everyone is a safe distance from the drone and wearing protective glasses.

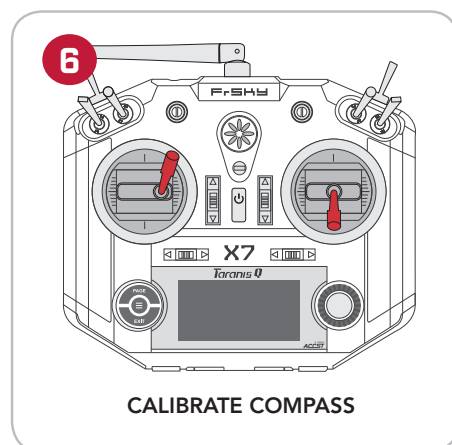
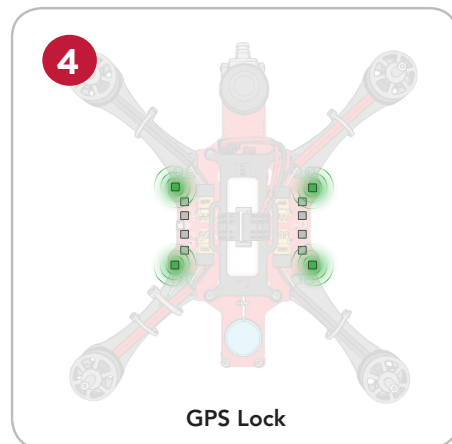

10. Conduct an initial flight test. Reconnect the battery on a flat surface and re-establish GPS lock. Power on the radio controller and communicate with all observers before arming the drone and during lift-off. *Arming the drone sets the "home" position for Return to Launch.*

- Start in Angle Mode and lift off a few feet from the ground. Test that the drone responds to throttle, pitch, yaw and roll as expected.
- Activate Altitude Hold and make sure the drone maintains its distance from the ground.
- Activate Position Hold. Without any additional stick input, RubiQ should be able to maintain a hover.
- Deactivate Position Hold, fly a short distance away and then trigger Return to Home to make sure the GPS is functioning as expected. If RubiQ returns to the "home" position as expected, she's ready to fly. *If you encounter issues with Position Hold or Return to Home, re-calibrate the compass and attempt the flight test again.*

11. Set your desired flight modes. After RubiQ has passed the initial flight test, adjust the radio switches to set the flight mode. (See Field Notes section for recommended options.) *Note: RubiQ will not arm if Position Hold or Return to Home are active. Ensure both features are turned off during lift off.*

After landing, make sure the throttle is down, and the motors are disarmed before approaching the drone. Unplug the LiPo battery *before* powering down the radio controller to avoid triggering the drone's failsafe. If the radio is shut down first, Rubi thinks she's lost radio connection and will steadily beep until a radio connection is restored.

Something not working right? Visit rubi.edventures.com/troubleshooting/ for tips to address common challenges.

RUBIQ POST FLIGHT INSPECTION



Disarm the drone before beginning inspection.

1. Check the LED's for any warning messages, then disconnect the battery. Inspect the LiPo battery for any serious physical damage, such as punctures or puffiness, which would require replacing the battery.
2. Remove all props and check for any that are bent, nicked or broken. These will need to be replaced before the next flight.
3. Check that all exposed wires are intact. If any have been nicked, wrap them with electrical tape and order replacement parts.
4. With the hex driver, confirm that screws are still firmly attached and tighten any that feel loose.
5. Inspect RubiQ's other physical components, including:
 - *Arms, PDB, Frame and Camera Mount:* Look for cracks or other signs of a hard impact.
 - *Camera, VTX Antenna and VTX:* make sure the SMA connection to the antenna is still snug, that the VTX is still connected and fully seated and with the props still removed, plug in the battery to make sure the FPV goggles are still receiving video feed from the camera.
 - *Motors:* with the props still removed, slowly spin the motors using the radio controller or the Master Control in INAV's Motor tab. Use your hand to gently feel for any free spinning motors. There should be no rough spots or squeals.
6. Charge the batteries and securely re-attach props and batteries before next flight.

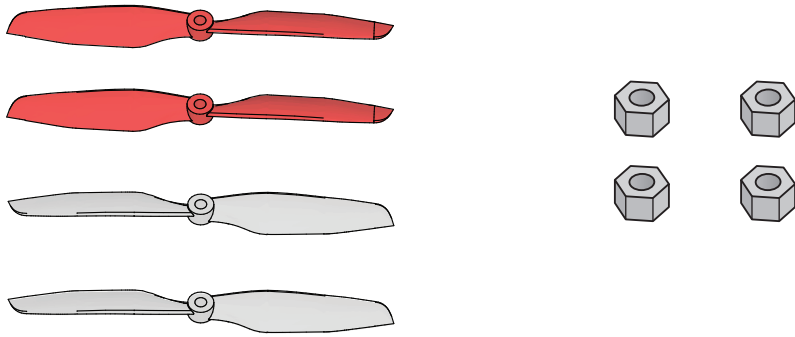

ASSEMBLY



CAUTION

Keep props off when building or configuring the drone.

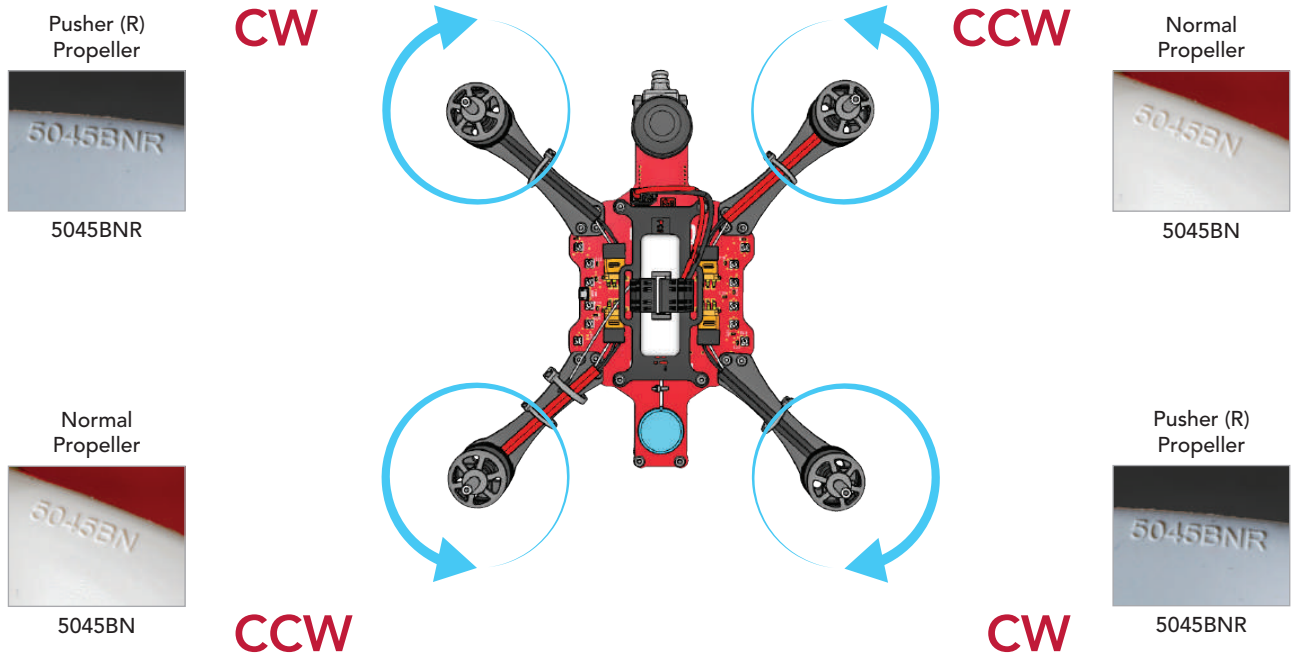

Check the coding printed on each propeller to pair CW and CCW props with the corresponding motor assembly.

ASSEMBLY

1

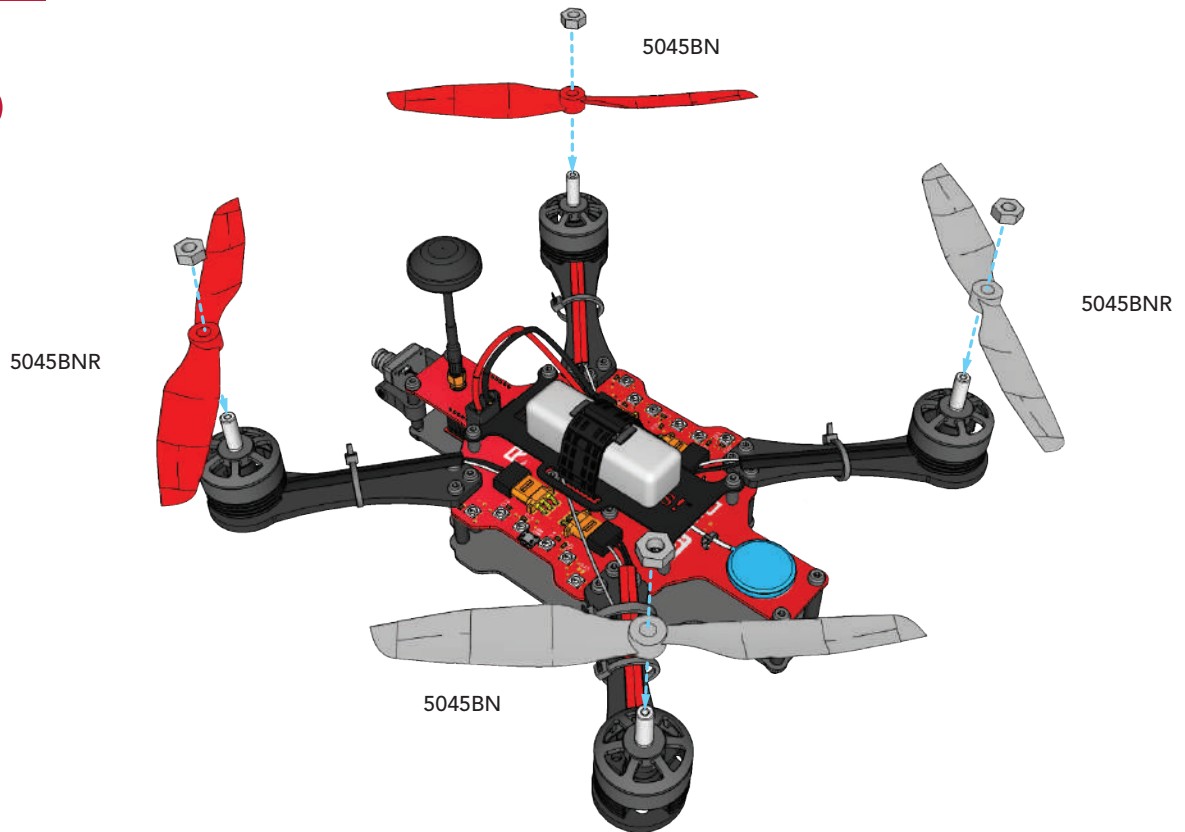

2



CAUTION

Attach prop nuts as firmly as possible. If the props spin independently from the motors, they aren't tight enough.



FIELD NOTES

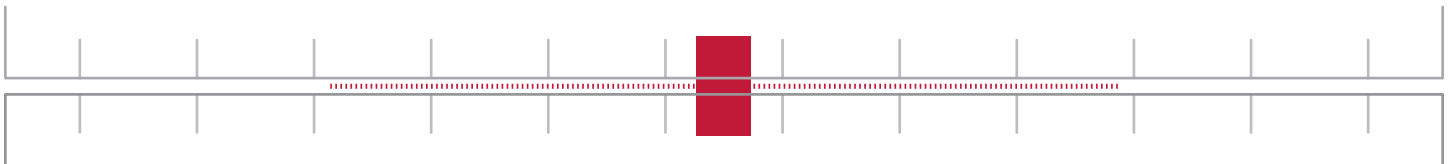

FLIGHT MODES

ACRO MODE/RATE MODE: allows for acrobatic FPV piloting. This mode requires full manual control since it does not auto-level and is only recommended for advanced pilots looking to start racing.

ANGLE MODE: is an assisted, self-leveling mode for beginner pilots.

ALTITUDE HOLD: allows the drone to maintain a constant altitude. When this mode is triggered, it takes the current throttle position as a hovering point. Moving the throttle above and below that position will still cause the drone to move up and down, but the climb and descent rate is noticeably slower than in Angle or Acro mode. If Altitude Hold is triggered when the throttle stick is too low (such as when the drone is on the ground), the flight controller will set the neutral throttle position to the middle position, so that moving the sticks above center causes the drone to climb and moving the sticks below center makes the drone descend.

POSITION HOLD: allows the drone to maintain a horizontal position. Combined with Altitude Hold for the Z axis, Position Hold can create a 3D lock. Roll and pitch can still be used to maneuver the drone, but when the sticks return to center, the position hold will resume. Like Altitude Hold, the slower rates in Position Hold create a gentle flight mode for first-time pilots.

RETURN TO HOME/RETURN TO LAUNCH: allows the drone to auto pilot itself back to the “home” position, the place where the drone was armed. If the drone is below 10 meters/32 ft when Return to Home is triggered, it will climb, fly straight to the “home” coordinates, descend and land itself. Above 10 meters/32 ft, Rubi will stay at her current altitude as she flies to the “home” coordinates, then descend and land. Manually disarm the drone once it’s on the ground.

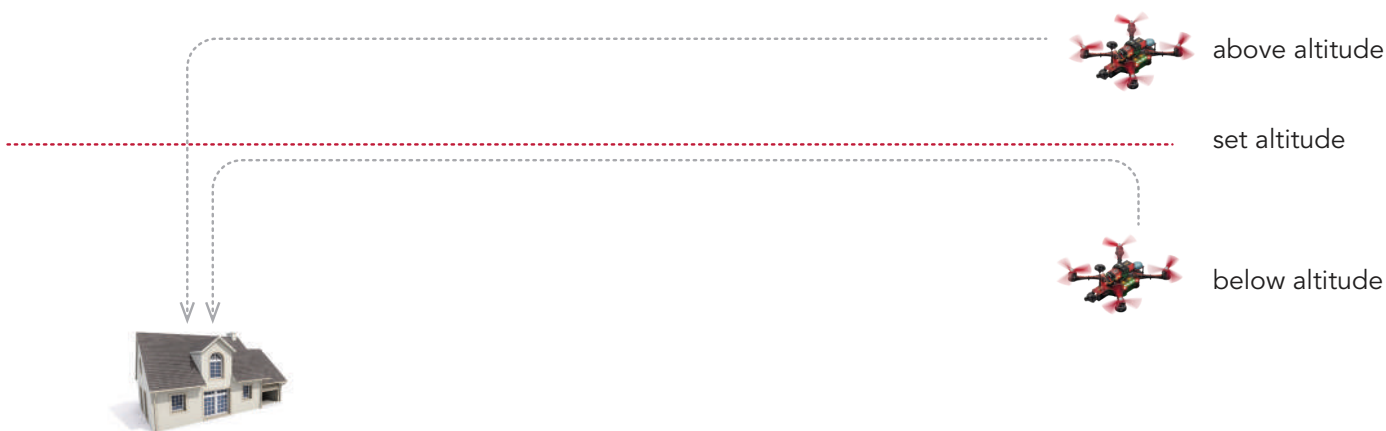

Rubi can be armed in any of the three primary flight modes: Acro, Angle or Altitude Hold. The other two modes, Position Hold and Return to Home, can only be activated after she has been armed.



FAILSAFE:

The default failsafe, which will activate if the drone ever flies out of range or the radio powers down mid-flight, is for the drone to shut off its motors rather than fly away uncontrolled. Keep in mind that if you lose connection to your radio, your drone will drop out of the sky, so never fly over people, buildings or property that could be damaged.

FPV BANDS AND FREQUENCY CHANNELS

RubiQ's VTX transmits on Band A, which is the following set of frequencies:

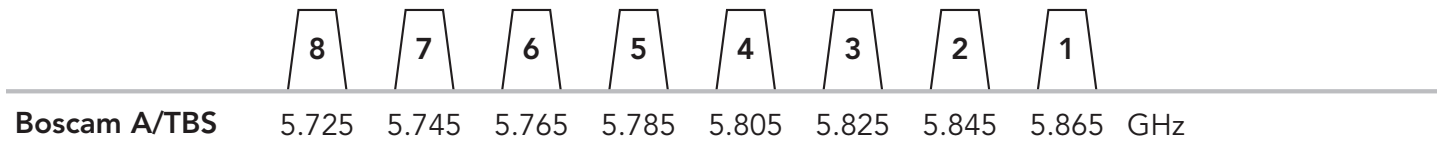

The position of the dip switches on Rubi's PCB sets the frequency channel for the video feed from the camera.

	1	2	3	
CH1: 5.865 GHz	ON	ON	ON	
CH2: 5.845 GHz	ON	ON		
CH3: 5.825 GHz	ON		ON	
CH4: 5.805 GHz	ON			
CH5: 5.785 GHz		ON	ON	
CH6: 5.765 GHz		ON		
CH7: 5.745 GHz			ON	
CH8: 5.725 GHz				

If more than one drone is powered on at the same time, be sure that each is set to a unique channel to avoid video interference. At least two channels of separation are recommended when more than one drone is in the air at a time.

RECOMMENDED FLIGHT MODES

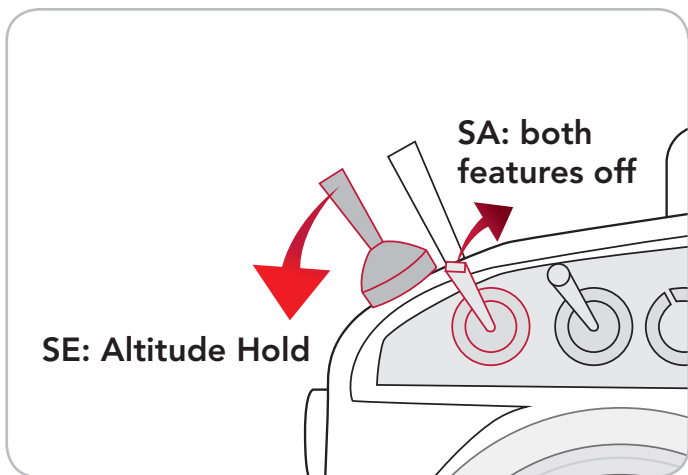

MAIDEN VOYAGES: Start in Altitude Hold. For an extra smooth flight, enable Position Hold shortly after lift-off.

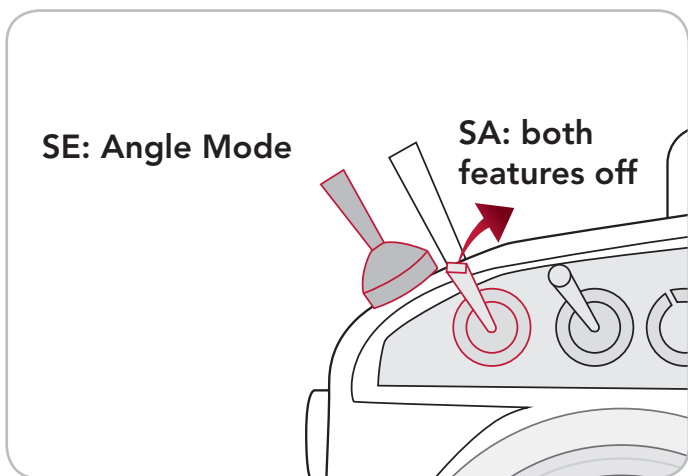

BEGINNERS: Start in Angle Mode.

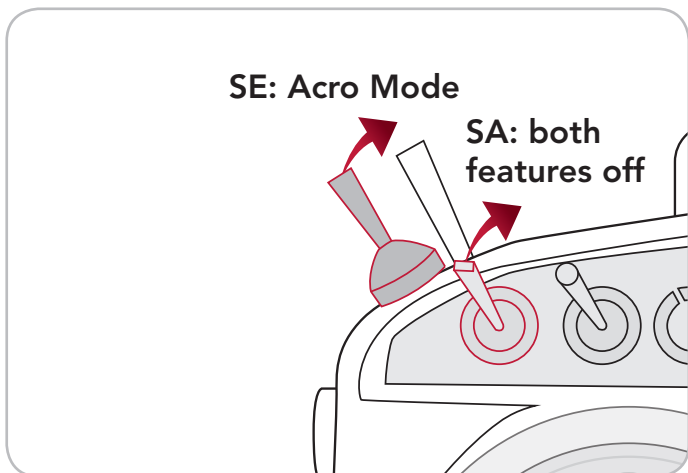

EXPERIENCED PILOTS: Start in Acro Mode.

RUBIQ LIMITED WARRANTY

Warranty Coverage

PCS Edventures warrants each new RubiQ education drone manufactured and sold to be free from defects in material and workmanship, when used in accordance with the technical instruction provided, for a period of 6 months from the date of shipment.

Within the period of this warranty, PCS Edventures will repair or replace, free of charge, any part proving defective in material or workmanship. All expenses related to repairing or replacing a defective part under this warranty (excluding shipping) shall be assumed by PCS Edventures.

How To Obtain Warranty Service

If repairs need to be made, contact PCS Edventures at (208) 343-3110 or send an email to rubiq@edventures.com with the following information:

1. Contact person and telephone number at which they can be reached.
2. School/organization
3. Purchase order and sales order #'s
4. As complete of a description of the problem as possible.

PCS Edventures will attempt to diagnose and resolve your problem over the phone. If PCS Edventures determines that your problem cannot be resolved remotely, PCS Edventures will issue an RMA (Return Merchandise Authorization) Form to be included with the returned items. Products returned without an RMA Form may not be covered under warranty. Products must be returned properly packaged to PCS Edventures. Damage to products that occurs due to inadequate packaging will not be covered under warranty. The Customer is responsible for all shipping charges to and from PCS Edventures. If PCS Edventures determines that the damage is covered under warranty, all expenses related to repairing or replacing the defective part, is covered by PCS Edventures.

If PCS Edventures determines that the problem is not covered under the warranty, PCS Edventures will advise the customer of the "not to exceed" cost of the parts, labor and return shipping.

Warranty Exclusions

This warranty does not apply to any costs, repairs or services for the following:

Damage caused by not following the technical instructions, plans and guides provided

Normal wear, including but not limited to crashes or piloting wear

Repairs resulting from misuse, abuse, accidents, alterations, improper assembly or operation above rated capacities

Damage caused by mismatch or misuse of battery and charger

Corrective work necessitated by repairs made by anyone other than a PCS Edventures authorized service technician.

Equipment or goods not manufactured by the Seller but supplied through the Seller, including but not limited to radio controllers, FPV goggles and LiPo batteries, carry the warranty of the original manufacturer.

Limitation of Damages

The Seller's sole liability under this warranty shall be limited to either replacing or repairing without charge, at its factory or elsewhere at its discretion, any equipment or goods meeting this warranty, or at seller's option, refunding the purchase price. The Seller shall in no event be liable for any other direct or any special indirect or consequential damages of any kind under this contract or otherwise. This warranty constitutes PCS Edventures' sole liability. There are no other warranties, expressed or implied, including warranties of merchantability and fitness for a particular purpose. PCS Edventures shall not be responsible for any incidental or consequential damages arising from any breach of warranty.

This warranty gives you specific legal rights, and you may also have other rights, which vary from state to state.

International Shipping

International Customers are responsible for all clearance fees, duties and taxes determined by customs in addition to all shipping charges.

THE SKIES ARE CALLING ISN'T IT TIME YOU ANSWERED?

Visit edventures.com for:

- Spare Props
- Extra Batteries
- Replacement Parts
- Flight Simulator Licenses
- Droneology Access Codes



READY FOR SOME REAL SPEED?

Upgrade to the
Gold Standard of
Drone Racing with the
Riot 250R Pro!



PCS **edventures!**™

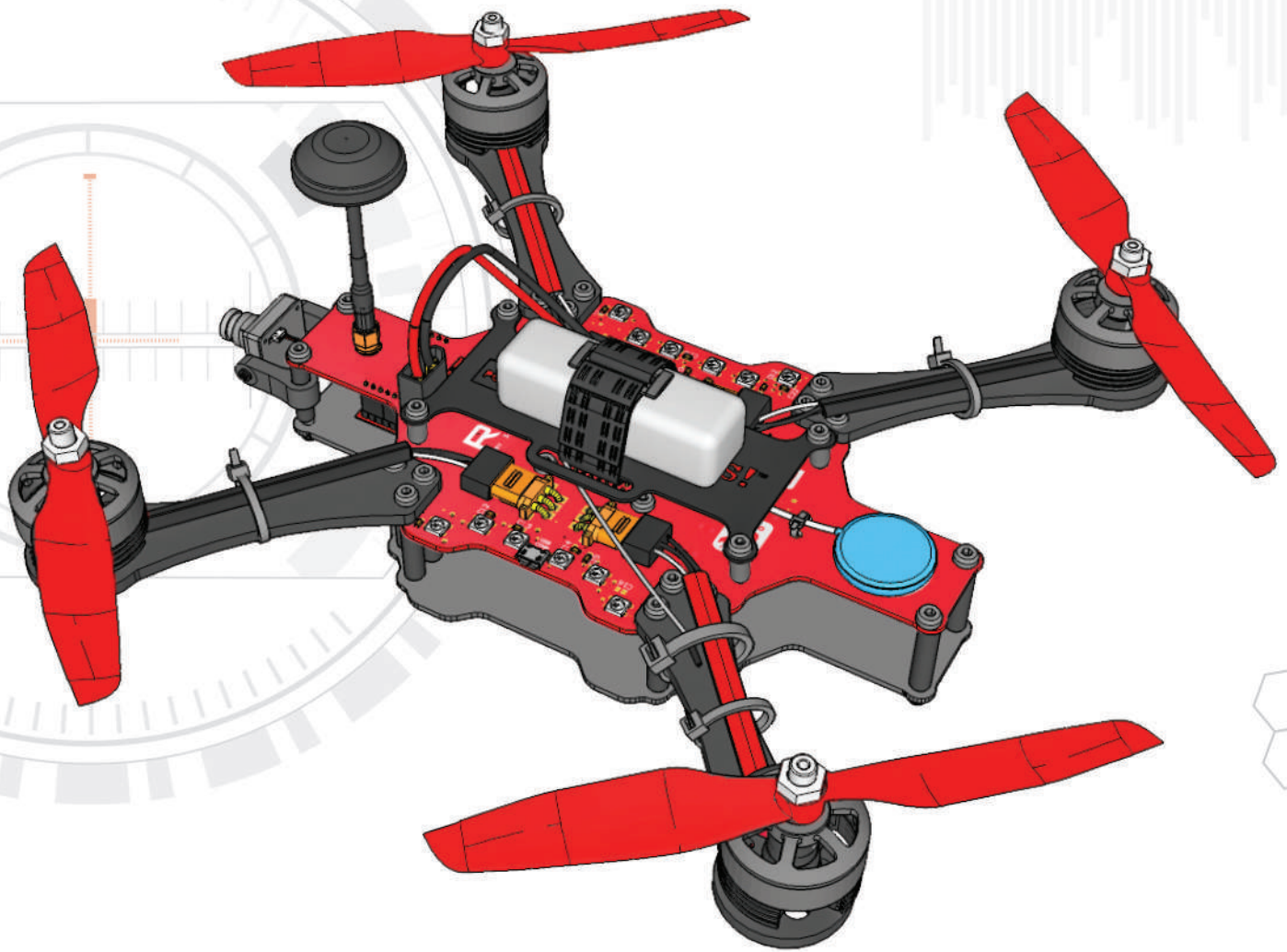

www.edventures.com